



2025 STAR MASTERS ZAGARINO CUP

Coral Reef Yacht Club, Miami, Florida

February 1-2, 2025

NOTICE OF RACE

1 Rules

- 1.1. Each Regatta in the Series will be governed by the *rules* as defined in *The Racing Rules of Sailing* (RRS).
- 1.2. The Organizing Authority is Coral Reef Yacht Club in conjunction with the International Star Class Yacht Racing Association (ISCYRA). The host fleet is Biscayne Bay Fleet 20.
- 1.3. The following US Sailing prescriptions will apply: The prescription to RRS 88.2, Appendix R, the prescription to the preamble to Part 5, and the prescriptions to rules 65.1, 70.3(b) and 76.1. The full text of the Prescriptions will be posted on the Official Notice Board (ONB).
- 1.4. STCR 35.5 changes the Two-Turn penalty in RRS 44.2 to a One-Turn Penalty.
- 1.5. RRS A4.1 will be changed to provide that a boat failing to check in prior to the warning signal of their first race of each day will be scored the same as a boat not starting in that race without a hearing.

- 2 Sailing Instructions:** The Sailing Instructions will be available on line *only* after January 30th, 2025.

3 Communication

- 3.1. The Official Notice Board <https://starclass.org/calendar/details/2025-zagarino-masters>.
- 3.2. [DP] STCR 31.2.6 allows, and it is strongly recommended, for VHF radios to be carried on all boats for the sole purpose to listen in to actions of the Race Committee and to transmit in the event of an emergency on a specific channel designated in the Sailing Instructions. On the water, the Race Committee may make courtesy broadcasts to competitors on VHF channel 71. Failure to do so by RC or the order in which boats are notified shall not be grounds for redress.

4 Eligibility and Entry

- 4.1. Entries eligible in accordance with STCR 21 and 26 may compete.
- 4.2. The skipper for each boat shall have reached the age of 50 by the start of the first race.
- 4.3. On time entries shall be submitted only on the [Official Online Entry Form](#) not later than 1800 hours on the day prior to the first race. Late entries (see NoR 5.4) will apply thereafter.
- 4.4. Only skippers and crew eligible to compete under the World Sailing Eligibility Code shall be eligible to compete in this regatta.
- 4.5. For the purpose of RRS Appendix A Scoring: A competitor is not considered an entry until all fees are paid.

5 Fees & Registration

- 5.1. Registration will be available online *only* at
- 5.2. The entry fee for the Regatta is \$350 per boat.
- 5.3. Entry fees include the Saturday evening Zagarino Memorial Dinner, boat and trailer launching, hauling and storage commencing at 0800 the day before the regatta until 24 hours after the conclusion of racing. Alternate storage and launching may be available next door at the US Sailing Center. <http://www.usscmiami.org/>
- 5.4. A \$25 late fee will be assessed to anyone signing up after 1800 hours January 30 up until 0930 hours February 1, when registration ends.

6 Advertising: Boats may be required to display event advertising on the forward part of the hull.

7 Schedule of Races:

- 7.1. The scheduled time of the warning signal for the first race on Saturday, February 1 is **1125** hours and Sunday February 2 is **1055** hours.
- 7.2. Maximum of **three** races; one race must be completed to constitute a regatta.

8 Venue: Racing will be conducted on Biscayne Bay approximately 1 to 3 nm south of Dinner Key Channel entrance Mark "1".

9 Courses:

- 9.1. Courses will be according to STCR 34. Courses marked with a "V" after the Course Number will include the Vertical Offset at Mark 1 (see Attachment 2).
- 9.2. The diagram in the 2024 Star Log for Course 6 (STCR 34.3.7) is changed to delete the second pass of Mark 3 (immediately prior to the Finish).

10 Scoring:

- 10.1. The Scoring System in RRS Appendix A will apply, changed so that the regatta's score will be the total of her races scored (no discard).

11 Haul-out Restrictions: The Organizing Authority may impose haul-out restrictions.

12 Team and Private Support Boats: A yacht shall receive no outside assistance from support persons while racing. Towing to and from the race course area is permitted.

13 Prizes

- 13.1. Perpetual Frank Zagarino Trophy will be awarded and shall remain in CRYC's custody.
- 13.2. Prizes will be awarded to the skipper and crew for Masters (Skipper must have turned 50 before the start of the first race), Grand Master's (Skipper must have turned age 60 before the start of the first race), and Exalted Grand Master (Skipper must have turned age 70 before the start of the first race).
- 13.3. The Organizing Authority and/or Race Committee reserve the right to provide additional prizes.

14 Risk Statement and Disclaimer of Liability: Competitors participate in the regatta entirely at their own risk. See Rule 3, Decision to Race, which states "The responsibility for a boat's decision to participate in a race or to continue to race is hers alone." By participating in this event each competitor agrees and acknowledges that sailing is a potentially dangerous activity with inherent risks. These risks include strong winds and

rough seas, sudden changes in weather, failure of equipment, boat handling errors, poor seamanship by other boats, loss of balance on an unstable platform and fatigue resulting in increased risk of injury. **Inherent in the sport of sailing is the risk of permanent, catastrophic injury or death by drowning, trauma, hypothermia, or other causes.** The organizing authority, the race committee, the ISCYRA, and the sponsors will not accept any liability for material damage or personal injury or death sustained in conjunction with or prior to, during, or after the regatta.

15 Insurance: Boats sailing in this regatta must be adequately insured against third party liability for racing risks (minimum \$300,000 coverage). Proof of insurance will be requested.

16 Information:

Star Fleet 20 Website
www.stardistrict20.org

Joe Kolisch
Coral Reef Yacht Club Race Committee Chairman
RaceCommittee@coralreefyachtclub.org

Stuart Hebb
District 20 Chairman
info@starwinter.com

Coral Reef Yacht Club
2484 S. Bayshore Drive, Miami, Florida 33133
(305) 858-1733

Attachment 1 to Notice of Race - COURSES

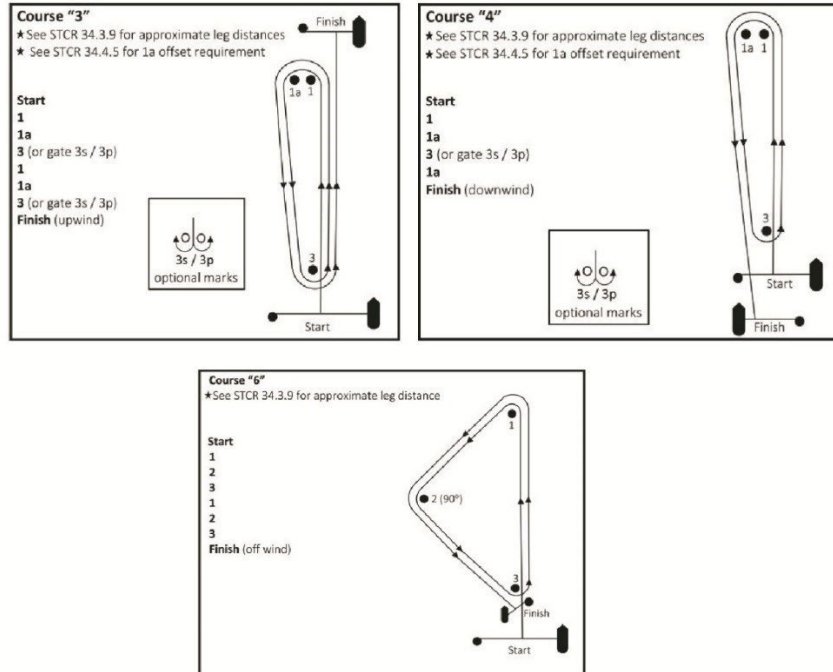

Vertical Offset

“O” Mark 1

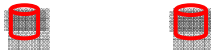

Mark 1A



Mark 3/Gate

This language is inserted in the course description:

The R/C will lay Mark 1A between 50 - 100 meters to leeward of Mark 1, and Offset Mark “O” at a 90° angle to the wind from Mark 1A at approximately the same distance. Boats shall pass in order Marks 1A, 1, “O”, and then 1A all to port before proceeding to the next Mark, per STCR 34.2. In the event of a change of course, all Marks can be moved to maintain the configuration of the course; Mark 1, Mark 1A, and/or “O” can be pulled entirely; or replaced by a mark boat. This changes STCR 34.3, Courses.